



---

BISON 5000A OWNER'S MANUAL

## **Preface**

Thank you for purchasing the BISON 5000A Air heater. This instruction book describes the structures, working principles, installation and operation of the BISON 5000A. For correct use of the heater please, please read this instruction book carefully before installation and use. The instruction book should be saved in a convenient place for later reference.

### **Attention**

- This instruction book is subject to revision without notice, but the instruction book is in conformity to the purchased product.
- Our effort is to explain all questions the user may have through this instruction manual. If you have any doubts or find anything incorrect in this manual, please contact the company directly.
- Check the heater for any damage when unpacking and contact the dealer immediately if any damage is found.
- If any troubles arise during application, please contact General Components or other customer service stations authorized by this company. We shall do our best to provide service to you.

## Contents

Introduction .....	5
Technical Data.....	6
Structure and Working Principle.....	6
BISON 5000A Internal Structure.....	7
Heater Cases .....	8
Installation .....	9
Installation of the Main Heater Body.....	11
Additional Ducting (Optional) .....	14
Installation of combustion air pipe and Exhaust .....	15
Installation of Fuel Lines .....	17
Installation of Fuel Standpipe .....	20
Installation of Electrics.....	22
Timer and Rheostat Control Plugs .....	24
Circuit Interfaces.....	26
Operation:.....	27
Rheostat Control.....	27
Mini Timer.....	27
Manual Start Up and Shut Down .....	29
Pre-setting Heating Time .....	29
Pre-setting Starting and Heating Times .....	29
Checking Temperature.....	30
Converting to Thermostatic Mode.....	30

Fault Information .....	30
Remote Operation .....	31
Installation Fuel Priming Feature .....	31
LCD Digital 7-Day Timer .....	32
Changing Language .....	33
Changing the Date and Time.....	34
Manual On/Off.....	35
Switching to Thermostatic Mode.....	36
Fan Mode .....	36
Pre-setting Heating Times.....	37
Installation Fuel Priming Feature .....	39
Checking Error Codes .....	40
Resetting Digital Controller to Factory Settings.....	41
Maintenance .....	42
Fault Codes:.....	43
Rheostat Control .....	43
Timers.....	44

Comply with the operation manual for installation and use to ensure prolonged and reliable operation.

## Introduction

The main equipment of the BISON 5000A Air Heater (hereinafter referred to as 'the heater') is a small fuel furnace controlled by a single-chip micro-processor. Its furnace body (the heat exchanger) is located in the hood shaped case, which serves as an independent air passage. Cold air is drawn into the air passage by the fan and blown out when it becomes hot.

The heat can be supplied by the heater to the driver's cab and passenger's compartment independently from the engine. The schematic diagram is shown in Fig I.

The heater is fully automatically controlled. It features a compact structure, easy installation, low running costs, easy maintenance and is safe and reliable.

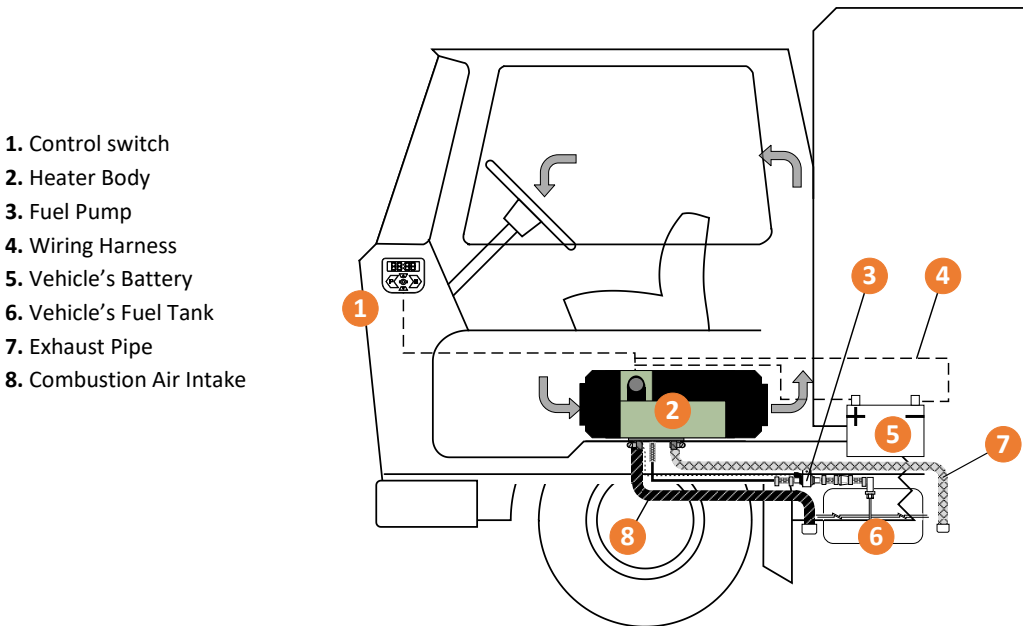

**Figure I**

## Technical Data

<b>BISON 5000A</b>	
<b>Heat Power</b>	5kW
<b>Fuel</b>	Diesel
<b>Rated Voltage</b>	12V24V
<b>Fuel Consumption</b>	0.19 - 0.60l/h
<b>Rated Power Consumption</b>	15 - 90W
<b>Working Temperature</b>	-40°C — 20°C
<b>Weight of Main Heater</b>	5.9Kg
<b>Dimensions</b>	425X148X162mm
<b>Mobile Phone Control (Optional)</b>	No limitation
<b>Remote Control (Optional)</b>	Without obstacles ≤800m

## Structure and Working Principle

The structure of the main body is shown in Figure II.

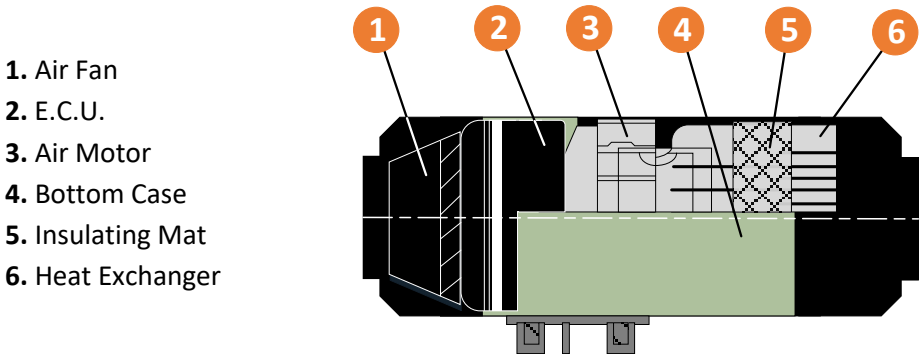

**Figure II**

## BISON 5000A Internal Structure

Figure III

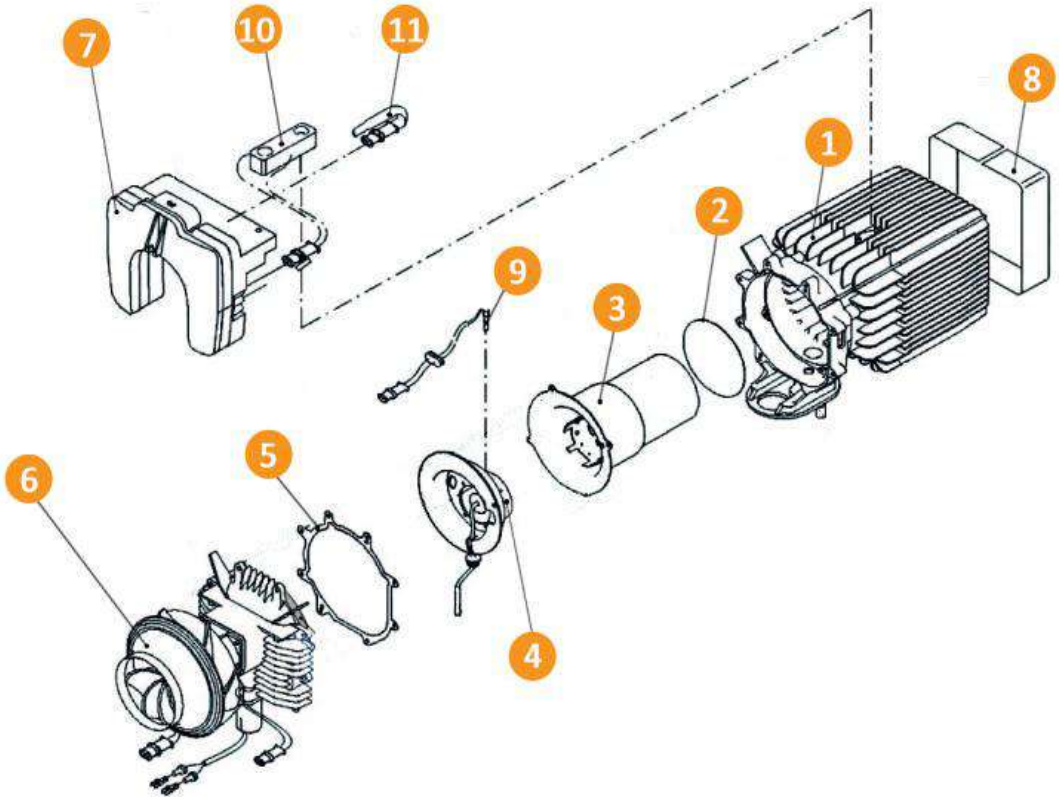

1. Heat Exchanger  
4. Burner Assembly  
7. ECU  
10. Overheat Sensor

2. O-ring  
5. Gasket  
8. Insulating Mat  
11. Temperature Sensor

3. Combustion Chamber  
6. Air Motor Assembly  
9. Glow Pin

The heat exchanger is made of die-cast aluminium with radiating fins around and at the rear end. The combustion chamber is installed in the inner cavity. The burner assembly is fixed on the front end of the combustion pipe. Fuel comes to the burner assembly through the fuel pipe and is ignited by the glow pin (which also serves as a flame sensor) after igniting. The flame enters the gap between the inner walls of the furnace body through the exhaust pipe vent.

The air supporting combustion of the furnace, comes from the combustion air inlet port and is sent down the combustion pipe by the combustion supporting air blades of the fan motor.

## Heater Cases

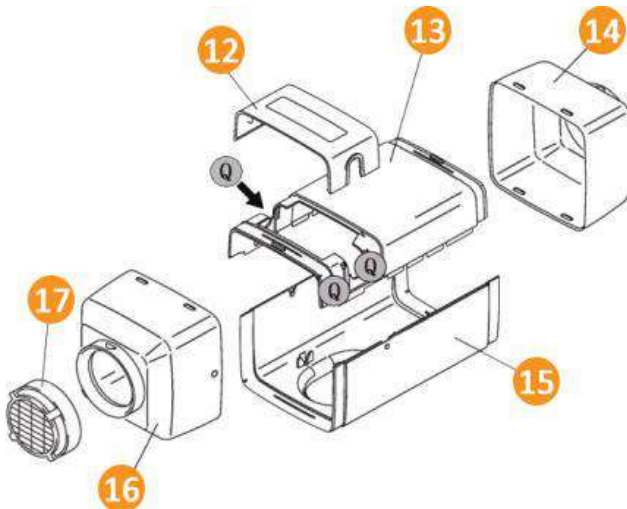

**Figure**

**IV**

**12.** Junction box cover  
**15.** Bottom Case

**13.** Top Case  
**16.** Inlet Case

**14.** Outlet Cover  
**17.** Grill



## Installation

The kit includes everything necessary for installation, it is recommended that you do not tamper or alter any parts straight out of the box.

### Exploded Parts Diagram

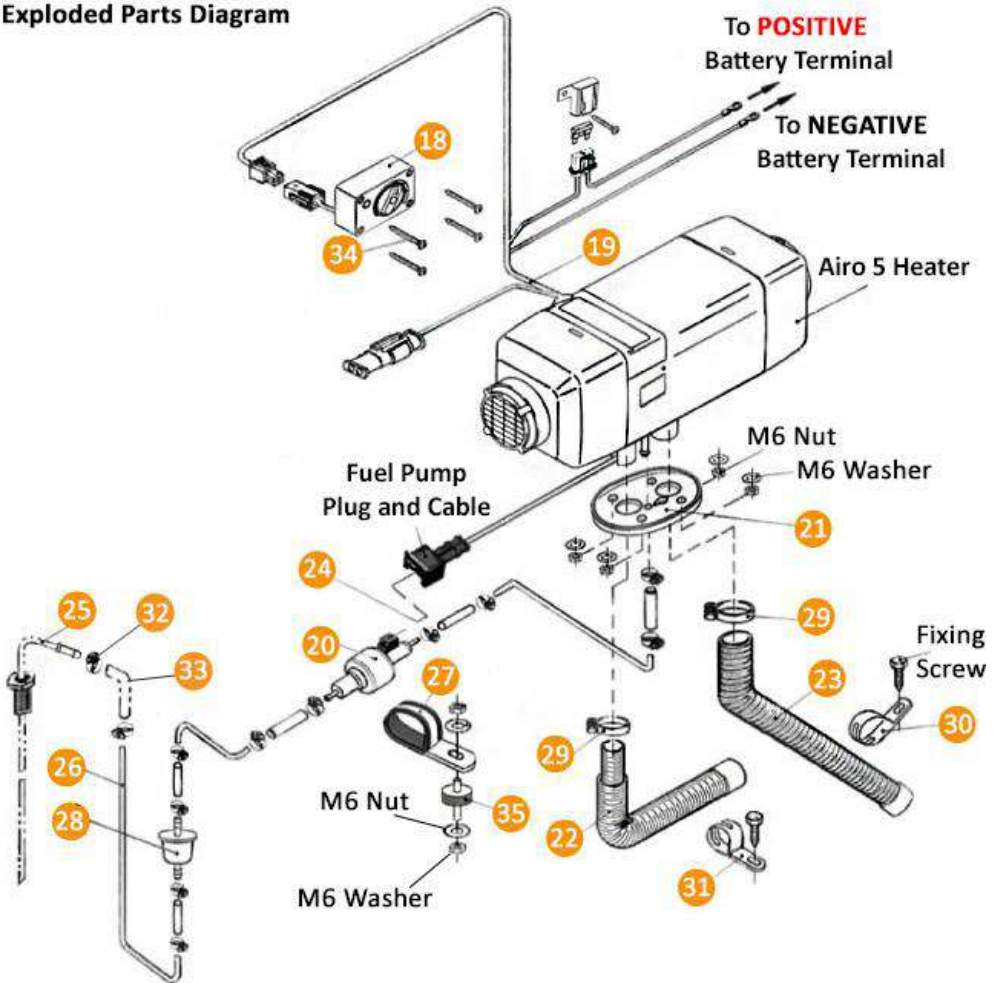

Figure V

1. Heater
3. Fuse holder
5. Fuse box cover
7. Control switch
9. Trouble diagnosis connector
11. Reducing T
13. Fuel pipe joint
15. Fuel filter
17. Fuel pump connector
19. Damper
21. Self-tapping screw
23. Air inlet pipe
25. M6 Nut
27. Gasket
29. Exhaust pipe
31. Manual button
33. Plug of remote control receiver or GSM receiver
34. Remote control receiver or GSM receiver
2. Main wiring harness
4. Self-tapping screw
6. Fuse
8. Connector X9 for control switch
10. Fuel suction pipe
12. Fuel pipe clamp
14. Fuel pipe
16. Fuel pump
18. Fuel pump leading wire
20. Fuel pump clamp
22. Air inlet pipe clamp
24. Air inlet pipe fixing clamp
26. Washer
28. Exhaust pipe clamp
30. Exhaust pipe fixing clamp
32. Remote controller

**Note:** The positions and ways of fixing various parts may vary from one vehicle to another, but the general principles remain the same.

**Attention:**

- Do not mount the heater near any flammable sources
- Do not install the heater in closed spaces without ventilation
- Do not place the heater near anything that can cause a blockage
- Do not mount the heater near any water sources and protect it from any splashing

## Installation of the Main Heater Body

For the ease of servicing, fault finding and air flow; it's recommended that the main body is placed in an area with easy access. Figure VI shows the minimum distances required.

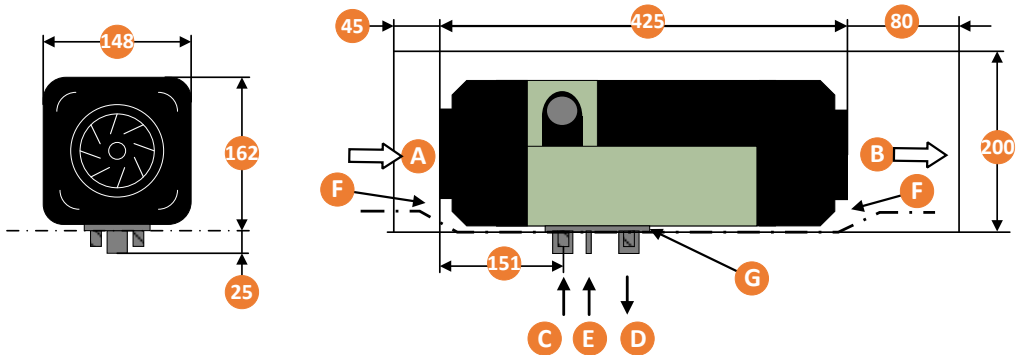
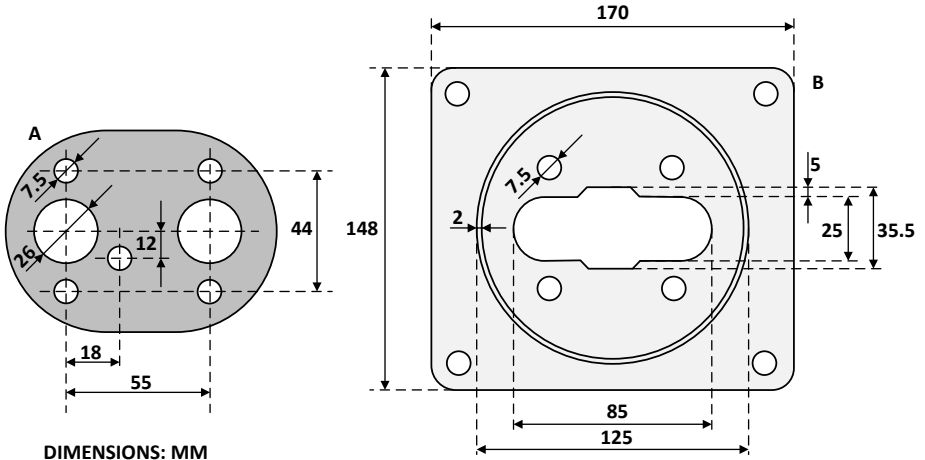

**Figure VI (Dimensions: mm)**

- |                                |                                 |
|--------------------------------|---------------------------------|
| <b>A.</b> Air inlet            | <b>B.</b> Air outlet            |
| <b>C.</b> Combustion air inlet | <b>D.</b> Exhaust outlet        |
| <b>E.</b> Fuel inlet           | <b>F.</b> Non-interference area |
| <b>G.</b> Installation Surface |                                 |

Choose a flat installation surface, any bumps will not ensure an even mount. Make sure there are no foreign bodies between the bottom of the heater and the installation surface itself. This will ensure a good seal between the two. Make sure to insert the gasket and the supplied mounting bracket between the heater body and the installation surface. File down any drill holes to again ensure an even mounting surface. Tighten the M6 bolts provided to a torque setting of 6Nm+1Nm.

Figure VII shows the position of the installation holes. If the installation area is less than 1.5mm thick a mounting plate will be required (Figure VIII).



DIMENSIONS: MM

**A. Mounting Gasket**  
**Figure VII**

**B. Floor Plate**  
**Figure VIII**

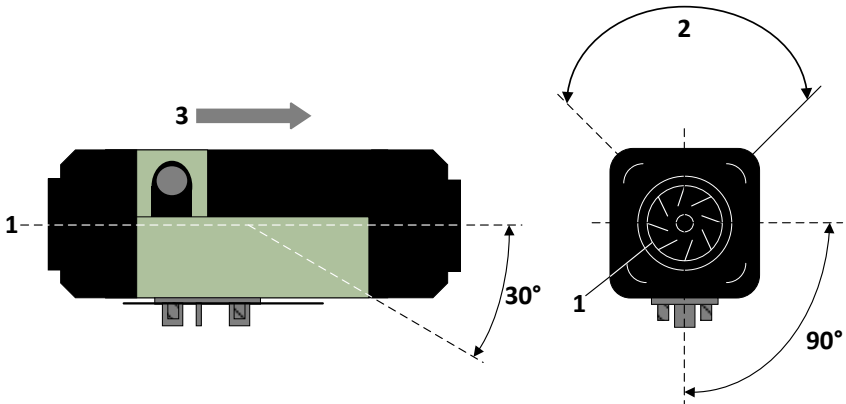

**1. Heater air intake**      **2. Glow pin position**      **3. Direction of air flow**  
**Figure IX**

The direction of the heater for installation is shown in figure IX.

Ensure you do not exceed the inclination angle or normal operation will be affected.

After installation, make sure there is no friction between the fan and other nearby parts to ensure smooth operation and make sure the heater label is clearly visible for ease of maintenance in the future.

### Hot Air Outlet

Make sure that the hot air outlet does not exit onto any parts affected by heat and that it isn't directed toward the flow of anything that can cause a blockage, near splashing water or near the vehicles exhaust.

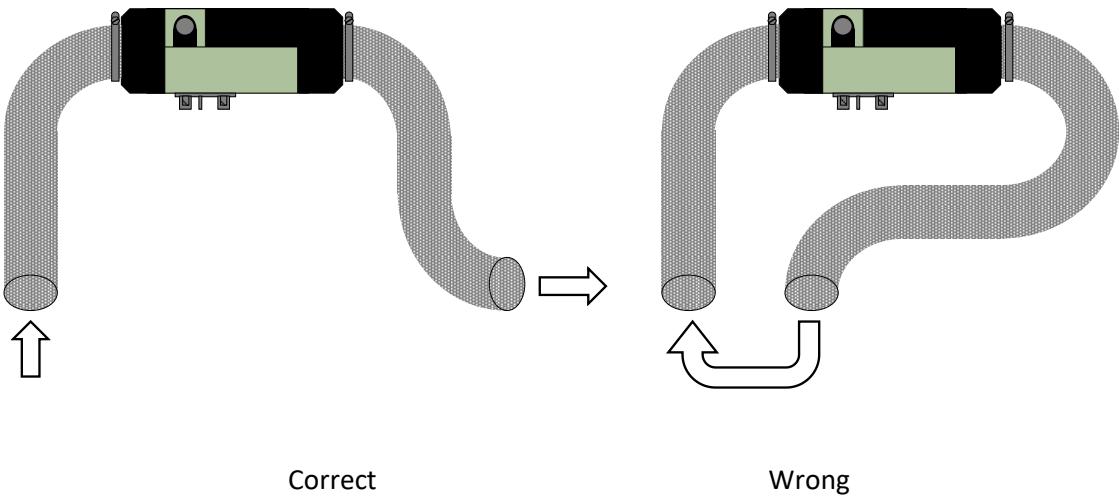
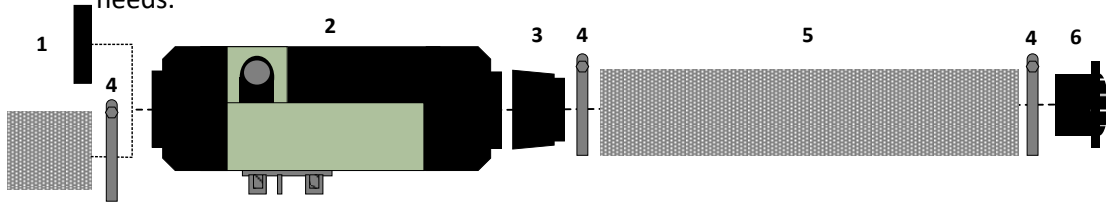

**Figure X**

Avoid re-entering of the supplied hot air into the inlet port (as shown in Figure X). If no inlet pipe is required, make sure the grill is installed at the inlet port instead (Figure IV no. 6).

## Additional Ducting (Optional)

Quantity of ducting can be purchased according to needs.



- |                            |                            |                                      |
|----------------------------|----------------------------|--------------------------------------|
| <b>1.</b> Grill or ducting | <b>2.</b> Heater Body      | <b>3.</b> 90-80mm Reducer (Optional) |
| <b>4.</b> 80mm Hose Clip   | <b>5.</b> 80mm APK Ducting | <b>6.</b> 80mm Directional Vent      |

**Figure XI**

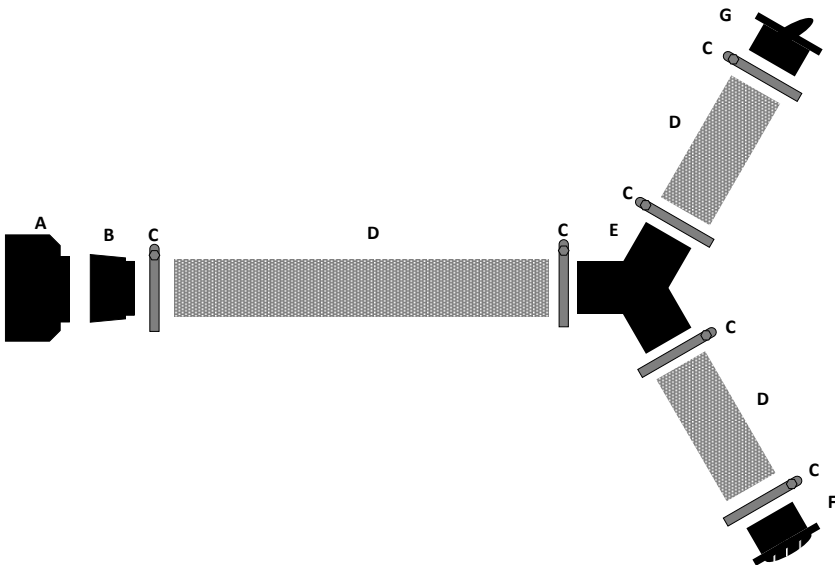

- A.** Heater Outlet **B.** 90-80mm Reducer (Optional) **C.** 80mm Hose Clip **D.** 80mm APK Ducting **E.** 80mm 'Y' Branch **F.** 80mm Directional Vent **G.** 80mm Open/Close Vent

**Figure XII**

## Installation of combustion air pipe and Exhaust

The combustion air inlet pipe sucks in fresh air from outside of the vehicle and the exhaust discharges fumes outside of the vehicle. Measures must be taken to avoid the fumes from re-entering the vehicle.

The pipes should exit at the bottom of the vehicle, ensuring that the openings are far enough away from any splashing water or dirt that can clog them.

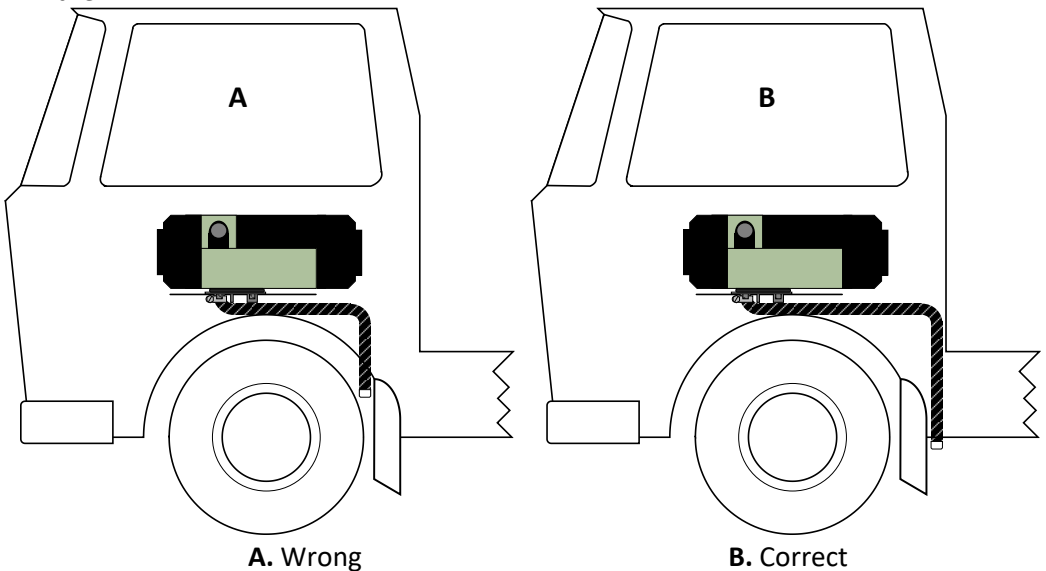
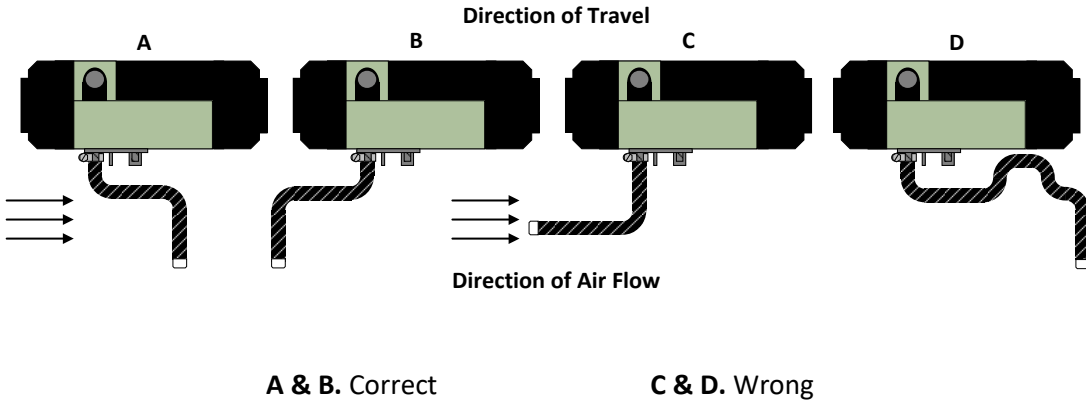

Figure XIII

Only use the inlet pipe and exhaust provided with the kit for installation. The exhaust pipe is made of corrugated stainless steel while the combustion pipe is aluminium covered in paper and plastic. **Do not** confuse the two. Use the supplied clamps to fix them securely to the combustion air inlet and the exhaust outlet on the heater. The protective end cap on the outlet of the combustion air pipe and exhaust pipe should be kept in good condition. Do not damage or remove them.

Both the combustion air pipe and exhaust pipe should come downward from the heater and face opposite to the vehicle's direction of travel. If the pipe cannot avoid a curve, make sure the radius is no smaller than 50mm and the sum of all curves does not exceed 270°.

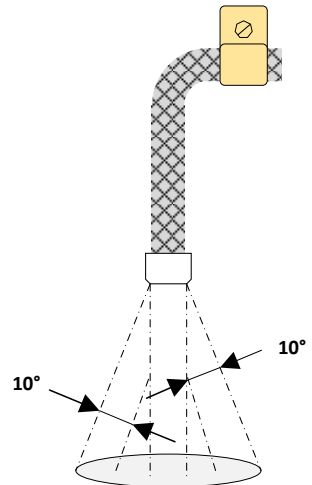

**Figure XIV**

When the heater is operating, the exhaust will get hot, so make sure it is installed away from any parts that could get damaged by high temperatures. The exhaust vent should also point downward to the road surface with an angle of  $90^{\circ} \pm 10^{\circ}$ . This is best achieved by fixing a clamp 150mm from the pipe end.

Any exposed exhaust should be covered with a heat shield to prevent scalding.

**Figure XV**





## Installation of Fuel Lines

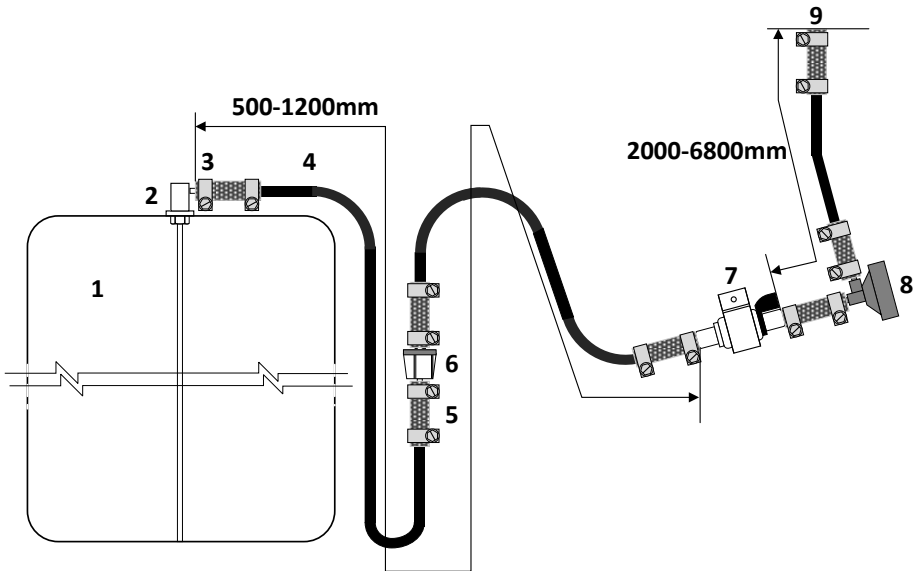

**Figure XVI**

- |              |                        |                                  |
|--------------|------------------------|----------------------------------|
| 1. Fuel Tank | 2. Fuel Standpipe      | 3. Fuel line connector hose clip |
| 4. Fuel Line | 5. Fuel line connector | 6. Fuel Filter                   |
| 7. Fuel Pump | 8. Damper              | 9. Heater Body                   |

The vehicle's own fuel tank can be used to supply the heater, a separate tank can be used if necessary. If a separate tank has been used, please ensure that it is not installed in the driver or passenger cab and is away from anything that could cause a fire risk or inhaling of toxic fumes.

Always fit the fuel pump on the anti-vibration mount securely onto the vehicle. Ensure the outlet of the fuel pump tilts upward. The correct angle is shown in figure XVII.

Where possible the fuel line is ideally placed uphill to the fuel pump to ensure ideal bleeding of the fuel line.

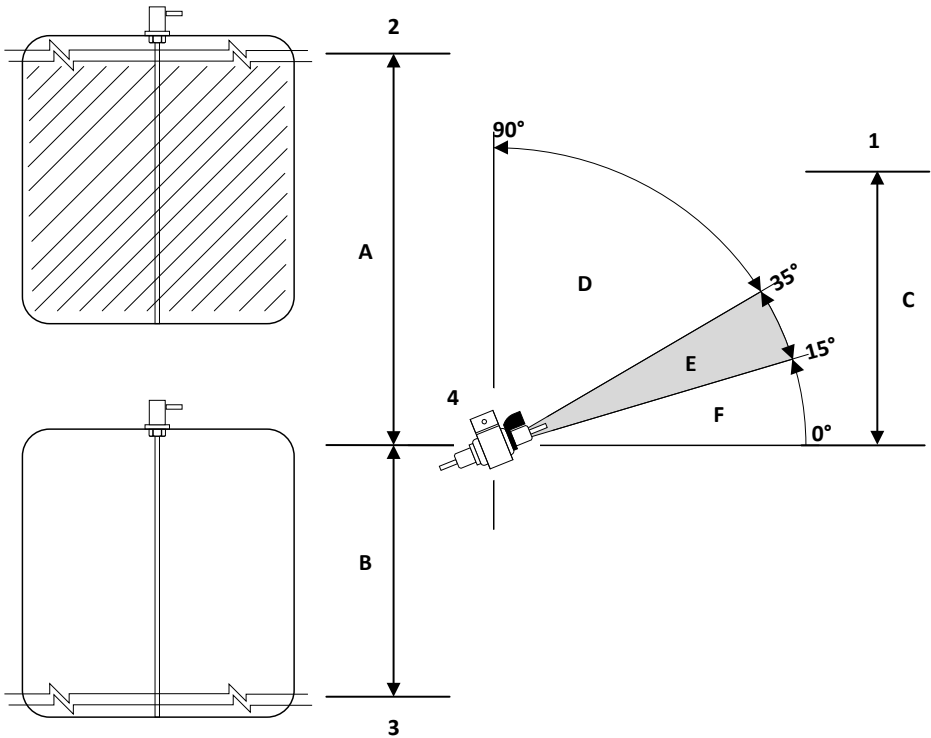

1. Heater Body  
 3. Min. Fuel Level

2. Max. Fuel Level  
 4. Fuel Pump

### Fuel Pump Angle & Suction Height

A. 3000mm  
 B. 500mm  
 C. 2000m  
 D. Not acceptable  
 E. Acceptable (between 15-90°)  
 F. Not acceptable

**Figure XVII**

Figure XVII shows the ideal way to mount the fuel pump. The fuel pump's outlet should tilt upward at an angle between 15°-35°.

Only use the fuel line provided, ensure the pipe is placed away from any possible debris and avoid any sagging in the line. Make sure the fuel line does not flow downward toward the fuel pump. This will prevent correct fuel flow and produce air bubbles in the line.

**The fuel filter, fuel pipe and clamps should all be replaced after 2 years of use.**

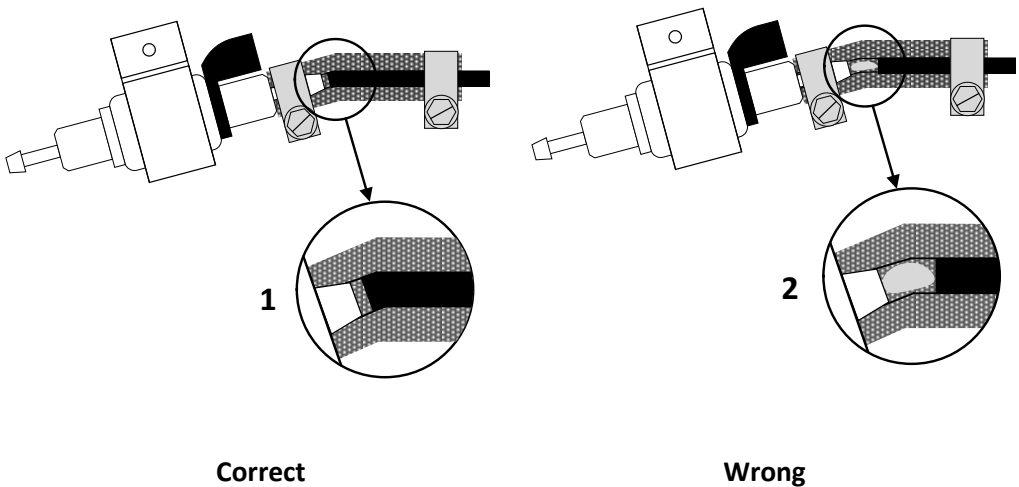

1. Fuel pipe clamp 2. Fuel pipe fitting 3. Fuel pipe

**Figure XVIII**

Figure XVIII shows the correct way to connect fuel lines to prevent the build-up of air bubbles, ensuring they are flush and minimising kinks.

## Installation of Fuel Standpipe

A fuel standpipe (or suction pipe) will need to be installed in the vehicle's fuel tank or an independent fuel tank depending on what the installation calls for. Sealant is not required to fit the standpipes.

Depending on the standpipe provide in the kit you will need to install the standpipe in one of two ways.

Standpipe 1: (Part No: AHZ-034)

Figure XIX



Usually supplied in Marine kits and supplied bent, this standpipe is installed like so:

- Drill a hole in the top of the vehicle's fuel tank  $\Phi 22 \pm 0.2\text{mm}$  in size. Ensure it is smooth and clean of burrs
- Remove the top nut and washers and bend the standpipe straight
- Cut the standpipe down to size if necessary
- Fit the standpipe by tilting it into position into the newly drilled hole
- Place the rubber and metal washers back on top followed by the nut and tighten it securely on top

Stand pipe 2: (Part No: AHZ-035)

Figure XX



Supplied mainly in vehicle kits, this standpipe is installed like so:

- If possible; remove the sender unit from the vehicle's fuel tank, this will make it easier to attach the nut securely back onto the standpipe
- Drill a  $\Phi 6 \pm 0.2\text{mm}$  hole into the sender unit
- Remove the nut from the standpipe and feed it through the hole ensuring the rubber 'o' ring remains on the standpipe 'head' side
- Replace the nut on the standpipe to secure it safely to the sender unit.
- Replace the sender unit into the fuel tank.

The bottom of the fuel standpipe should be 30-40mm from the bottom of the fuel tank to allow enough suction of fuel and at the same time not allow impurities and sediment to be drawn up the standpipe.

# Installation of Electrics

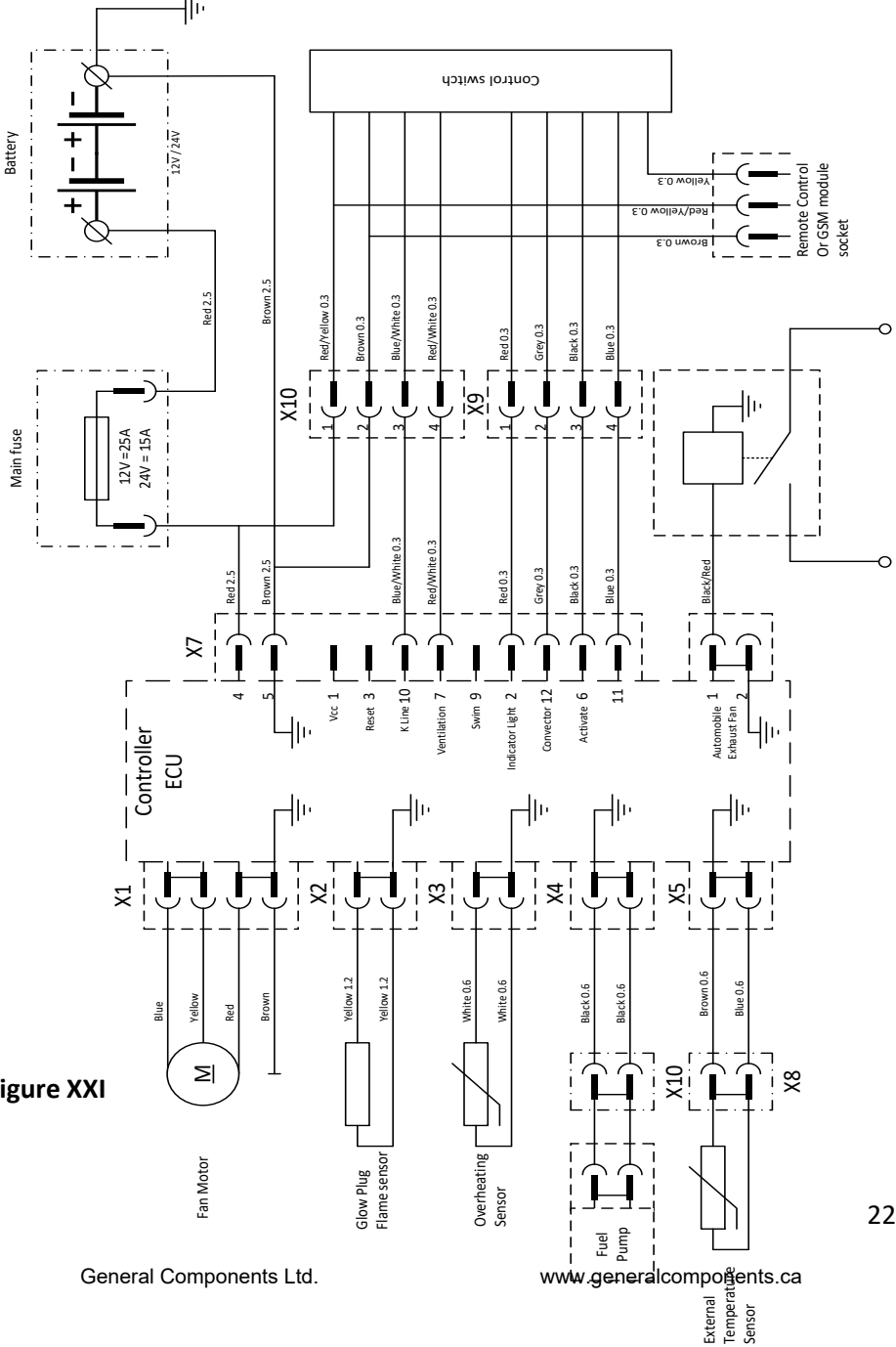

Figure XXI

Figure XXI shows the wiring diagram for the heater. The wires of the main heater have been made into bundles. They can be laid according to the positions of various components and should be fixed to the proper locations. The distance between two fixing points should not exceed 300mm.

**Note:** Any exposed wire outside the vehicle should be protected so as not to be ripped by any road debris etc.

Connect the main wiring harness to the heater by gently removing the junction box cover. Connect the 18-wire connector X6 of the wire bundle to the controller socket. The main harness can exit the heater to the left or to the right. Then replace the cover ensuring a good seal is kept all the way round.

A bladed fuse will already be inserted into the holder 'F' (20A for 12V versions and 15A for 24V). Use a screw to fix it in a suitable position on the vehicle.

Connect the 2.5mm<sup>2</sup> red wire and the 2.5mm<sup>2</sup> brown wire in the wire harness to the spring terminals and then to the positive and negative of the vehicles battery.

Straighten the fuel pump leads (two 0.6mm<sup>2</sup> black wires) and put them through the opening on the wall of the combustion air inlet pipe of the heater. Then insert the plug to the spring terminals of the fuel pump connector.

## Timer and Rheostat Control Plugs

Use a single screw to fix the timer control or rheostat control in place. They are best installed so that they can be seen and operated easily to identify working conditions and for easy access. The black and clear plugs connect to the corresponding plugs on the loom (below). The remaining three-pin socket on the timer or rheostat control plugs into the remote-control receiver if one is installed. An adaptor cable may be necessary.

### Timer Control Plug

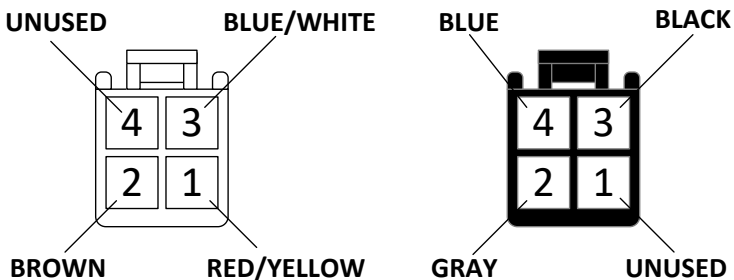

To Timer Control  
 Figure XXII

### Rheostat Control Plug

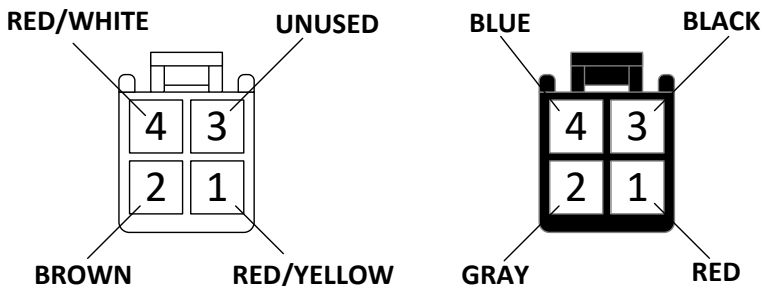

To Rheostat Control  
 Figure XXIII



## Wiring Loom Plug for Timer and Rotary Control

Figure XXIV

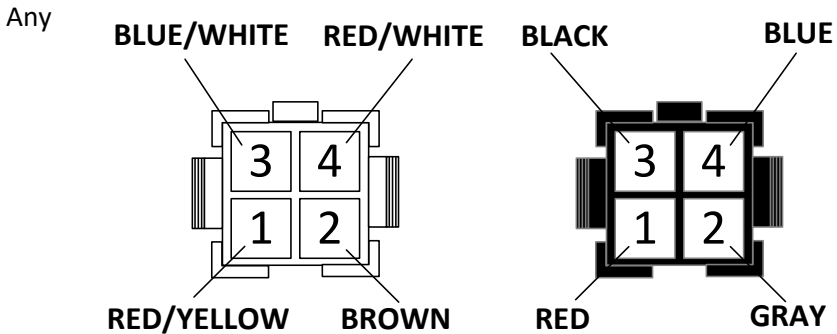

### To Main Wiring Harness

surplus wires should be kept in good condition and wrapped in electric tape to avoid short circuiting.

## Circuit Interfaces

The connection parts on the controller case are designed in such a way that wrong connections are impossible to make.

The following circuit interfaces can be found on the controller case, these are:

- X1: Fan motor
- X2: Glow plug/flame sensor
- X3: Overheat sensor
- X4: To fuel pump
- X5: Temperature sensor
- X6: Convector Motor
- X7: Main wiring harness

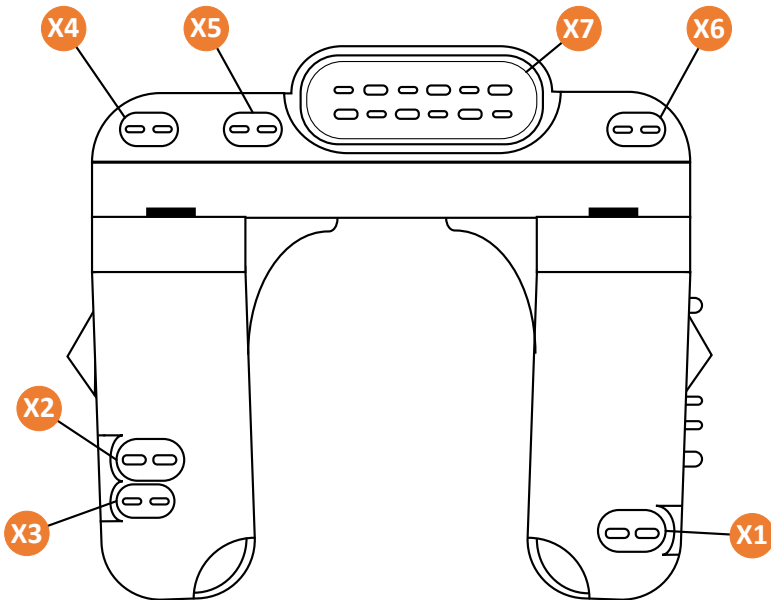
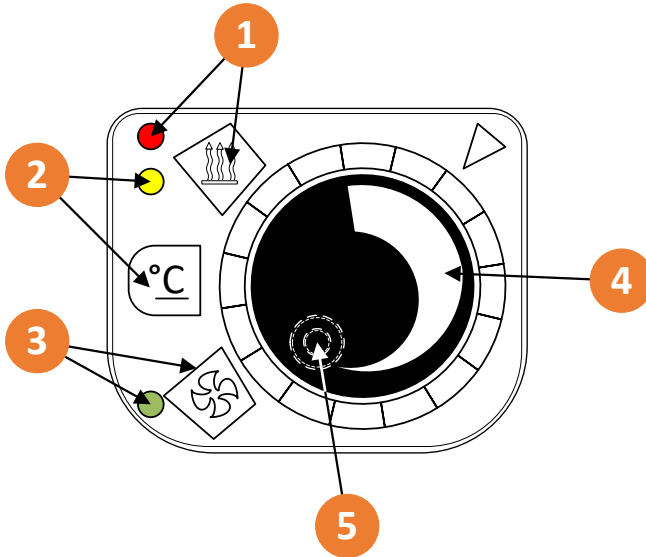

Figure XXV

## Operation:

### Rheostat Control



1. Variable Output Button and Indicator Light
2. Temperature Button and Indicator Light
3. Fan Only (Cold Air) Button and Indicator Light
4. Control Knob
5. Fixing Screw Hole (Located underneath control knob)

**Figure XXVI**

The rheostat (or rotary) control works by twisting the control knob to the desired heat setting, and using the buttons listed to determine the heaters function. Variable output is simply high to low heat. The temperature button switches the heater to thermostatic mode (the heater will then switch to a cool-down cycle automatically once it has reached the selected temperature). The fan button only switches the fan on for cool air.

## Mini Timer

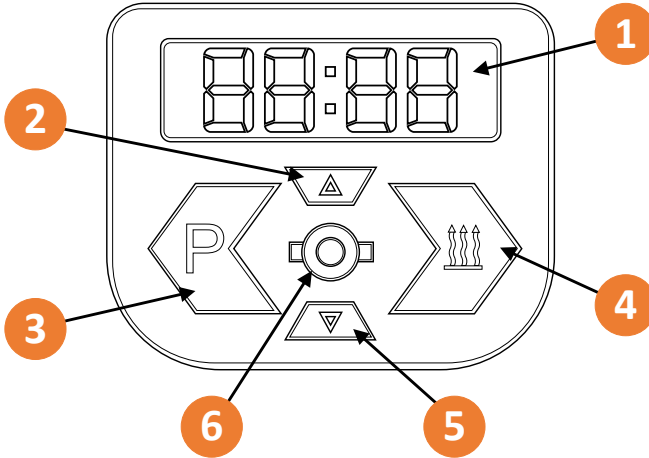

1. Display                      2. Up Arrow Key              3. 'P' Icon  
4. 'Heating' Icon            5. Down Arrow Key            6. Fixing Screw Hole

**Figure XXVII**

## Functions

- Adjustable thermostatic mode from 5°C to 35°C
- Adjustable 7 step heating mode from <1kW to your heaters full output
- 24-hour countdown set up time
- Heating time from 15 minutes to 99 hours
- Fault Information Codes

## Manual Start Up and Shut Down

For immediate start-up press the heating icon to change the standby mode into the heating mode and the heater will start up immediately.

To adjust the heating temperature in the heating mode simply press the up or down arrow keys.

To turn the heater off manually, simply re-press the heating icon.

## Pre-setting Heating Time

During heating mode, press the 'P' button and the down arrow simultaneously to start a countdown for the heating time.

Adjust the hour with the arrow keys and confirm the time with the 'P' button. Then adjust the minute time again using the arrow keys and confirm again with the 'P' button.

**Note:** The 'dot' in the upper right hand corner of the screen means the time was set successfully. To cancel press the heating icon.

## Pre-setting Starting and Heating Times

**Step 1:** Press the 'P' key in the standby mode to enter the pre-set mode.

**Step 2:** The time mode will appear. Adjust the hour first with the arrow keys and press the 'P' when complete to move onto the minutes. You can adjust the minutes in the same way, however ensure you press the 'heating icon' to confirm (the confirmation dot will appear in the upper right hand corner of the screen), then press the 'P' button to move onto the next step

**Step 3:** Next stage is the temperature/output stage, the two can be adjusted by pressing the arrow keys simultaneously. The modes can then be adjusted with the arrow keys. Once adjusted; confirm the selection by pressing the 'heating icon' and move onto the next step by pressing the 'P' button.

**Step 4:** Next step is adjusting the heating time. You can adjust this in the same way using the arrow keys. The hour first followed by the minutes, pressing the 'heating icon' again to confirm and the 'P' key for the final time to complete the task.

**Note:** The 'confirmation dot' in the upper right hand corner of the screen must be present each time a step is adjusted to confirm it.

## Checking Temperature

Pressing the 'P' and 'up' arrow button simultaneously whilst in the heating mode will display the air inlet temperature, or the remote temperature sensor probe's temperature if one is fitted.

**Note:**

- The display will show 0°C if the temperature is lower than 0°C
- The display will automatically revert to the heating mode if left idle for more than 5 seconds

## Converting to Thermostatic Mode

Press both arrow keys to manually change from the heating mode to the thermostatic mode.

## Fault Information

The fault display can be accessed by pressing the 'P' button during the heating mode.

Six fault codes can be checked by pressing the arrow keys.

To return to the heating mode, press the heating button.

To eliminate the fault information; press the 'P' and heating buttons simultaneously.

## Remote Operation

When the remote signal had been received, the timer will automatically switch to the thermostatic mode, with a default temperature of 25°C, the confirmation dot will appear in the meantime.

To return back to the standby mode, press the heating icon. The confirmation dot will continue to appear until the remote shutdown signal has been received.

## Installation Fuel Priming Feature

### ATTENTION:

- Not to be used in normal heater operation
- Disconnect the fuel line from the heater first, to prevent flooding of the heater and place in a suitable receptacle.

To enter the fuel priming mode, press and hold the 'P' icon for more than three seconds and let go to enter the next step.

Next, press and hold the heating icon for more than three seconds and then let go. If done correctly the display will read 'FUEL' and the pump will begin to pump quickly. To stop; press the heating icon again.

Press and hold the 'P' icon for more than three seconds to return to the standby mode.

## LCD Digital 7-Day Timer

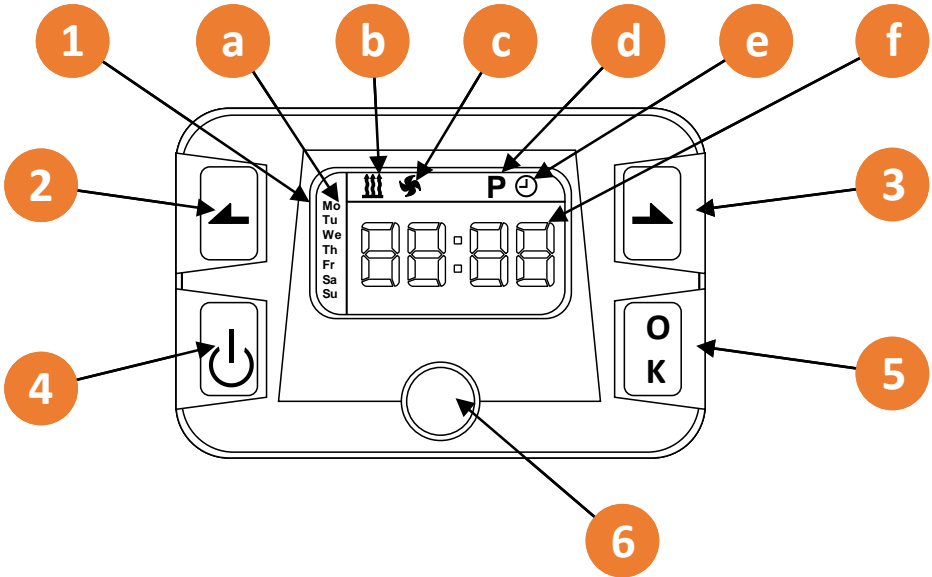

**Figure XXVIII**

- |                       |                                   |
|-----------------------|-----------------------------------|
| 1. LCD Screen         | a. Days of the week               |
| 2. Left Arrow Button  | b. Heating Symbol                 |
| 3. Right Arrow Button | c. Fan Symbol (later models only) |
| 4. Power/Back Button  | d. 'P' (Timer) Symbol             |
| 5. OK Button          | e. Clock Symbol                   |
| 6. Fixing Screw Hole  | f. Clock Face                     |

### Functions:

- 7 day timer, able to be programmed 3 times daily
- 7 step variable output mode
- Thermostatic mode from 05°C to 35°C
- Adjustable cold air fan mode (on later versions)



## Changing Language

The language should be set to English. However, if it isn't or the control has been reset to default settings it will revert to Chinese. Please follow these steps to convert the language to English.

1. Turn on the control with the power button. Wait for the symbols to stop flashing, then press the power button again.
2. Navigate to the clock face symbol at the top of the control by using the arrow keys. When it is flashing press both arrow keys simultaneously.
3. P1 now appears.
4. Press ok and C1 will appear.
5. Keep pressing ok slowly until '02:oF' appears.
6. Press any of the arrow keys until the screen reads '02:on'
7. Keep pressing ok until back to the P1 menu screen
8. Press power button to return. The language will now be set to English.

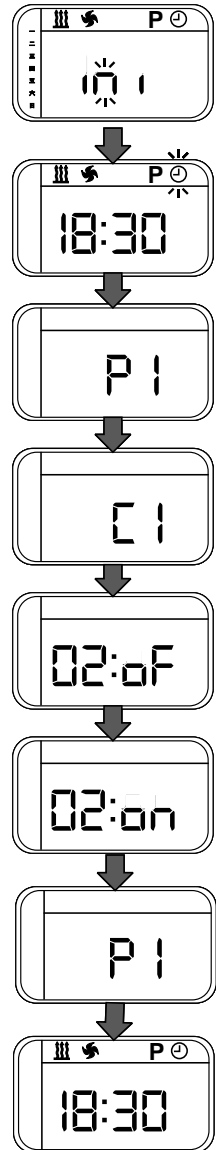

## Changing the Date and Time

1. To change the date and time, navigate to the clock face symbol and press ok.
2. Select the day of the week it is first using the arrow keys, and pressing ok to confirm.
3. Select the hour using the arrow keys, and pressing ok to confirm.
4. Finally, select the minutes in the same way.
5. Once completed, the control will return to the home screen (displaying the correct time)

**NOTE:** If the LCD digital timer is disconnected from the loom, the date and time will need to be re-entered.

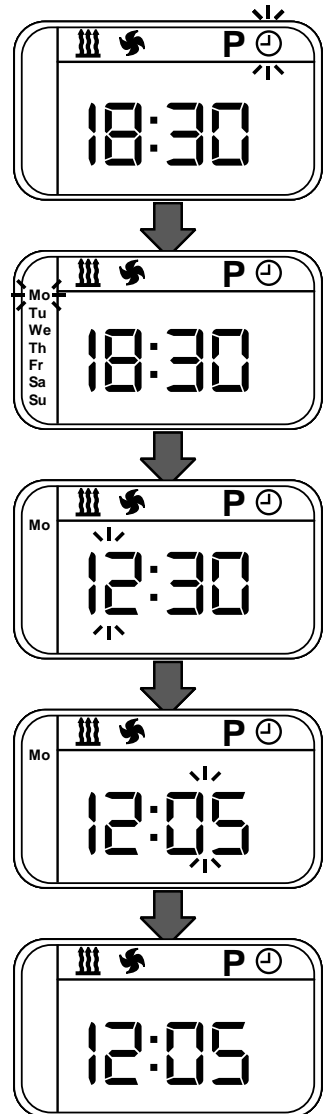

## Manual On/Off

1. To switch the power on manually, navigate to the heating icon, and press ok
2. The heater will start automatically.
3. Use the arrow keys to adjust the output of the heater from high to low (07 to 01 respectively)
4. To switch the heater off, simply press the heater button to return to the home screen.

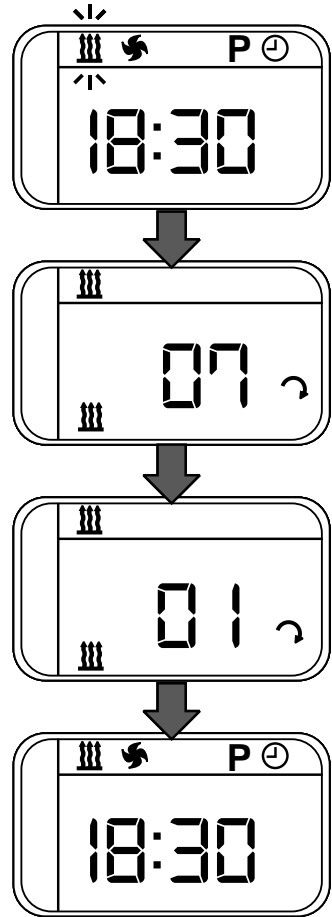

## Switching to Thermostatic Mode

To switch to thermostatic mode, turn the heater on manually, as stated in the previous step.

1. Once the heater is on, press and hold the ok button for three seconds and then release it.
2. The display should change to a temperature setting which can be adjusted from 05°C to 35°C using the arrow keys.
3. To adjust back to the variable output mode, simply press and hold the ok button again for 3 seconds and then release it.
4. To switch the heater off, press the power button to return to the home screen.

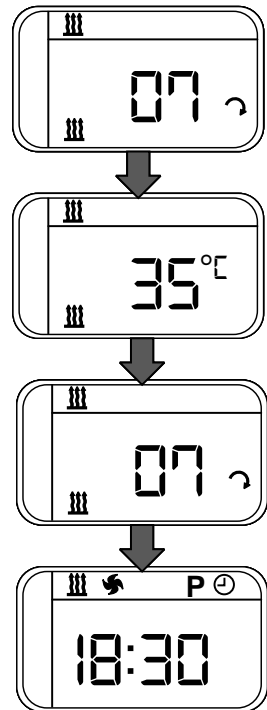

## Fan Mode

The fan mode works in the same way as the manual on/off mode. Simply navigate across to the fan symbol and confirm with OK. The fan will then automatically switch on and its speed can be adjusted from high to low (07 to 01 respectively) using the arrow keys. To switch it off, press the power button.

**NOTE:** Some earlier models will not have this function.

## Pre-setting Heating Times

The digital control can be used as a 7-Day timer, and is able to be preset to switch on up to three times a day.

1. Navigate to the 'P' symbol, and press OK.
2. Using the arrow keys select the number 1 (flashing) at the top of the screen, and press OK – Number 1 is the first heating time.
3. Using the arrow keys, select 'ON', as this will allow the heater to switch on after the presetting is finished. Press OK to confirm.
4. Select the length of time you want the heater to run for by using the arrow keys. – L800 represents 800 minutes. Run time can be selected from 50-990. Press OK to confirm.
5. Select the hour you wish the heater to start at by using the arrow keys and then pressing OK to confirm.

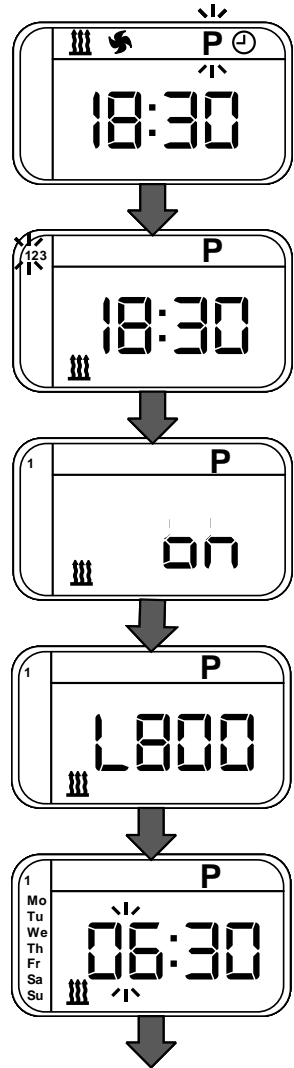

6. Select the minutes in the same way, and press OK to confirm.

7. The next step is choosing which day of the week you want the heater to run. Starting with Monday, use the arrow keys to change from 'OFF' to 'ON' and press OK to confirm. Continue this all the way through to Sunday.

8. The preset time should now be set. This will be indicated by the small, underlined number 1 at the top of the screen.

9. To set the second and third heating times, simply repeat all the steps but select 2 or 3 instead of 1 (see step 2.) to set those heating times.

**NOTE:** To turn any of the preset times off without altering the set times, simply go through to step 3 and select 'OFF' using the arrow keys. Then repeatedly press OK until you have returned to the home screen.

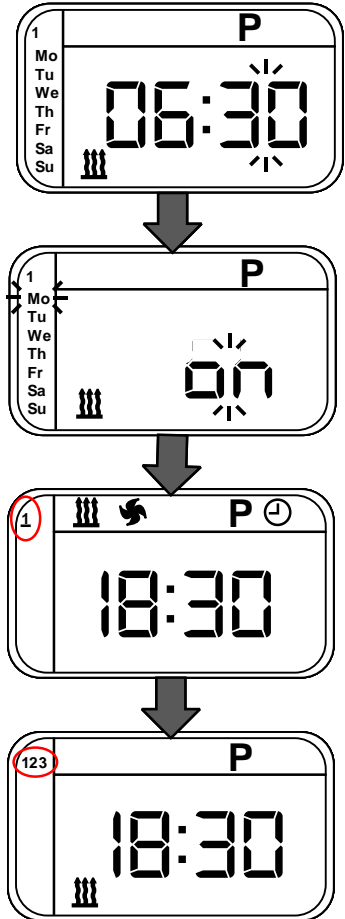

## Installation Fuel Priming Feature

### ATTENTION:

- Not to be used in normal heater operation
- Disconnect the fuel line from the heater first, to prevent flooding of the heater and place in a suitable receptacle.

1. To enter the fuel priming mode, navigate to the clock face using the arrow keys and press both arrow keys simultaneously.
2. P1 should appear on the screen.
3. Select P2 by pressing any arrow key, and confirm with OK.
4. The fuel pump will begin to rapidly pump the fuel.
5. It will automatically shut down after three minutes, or press any key to stop the pumping at any time, and return to the home screen.

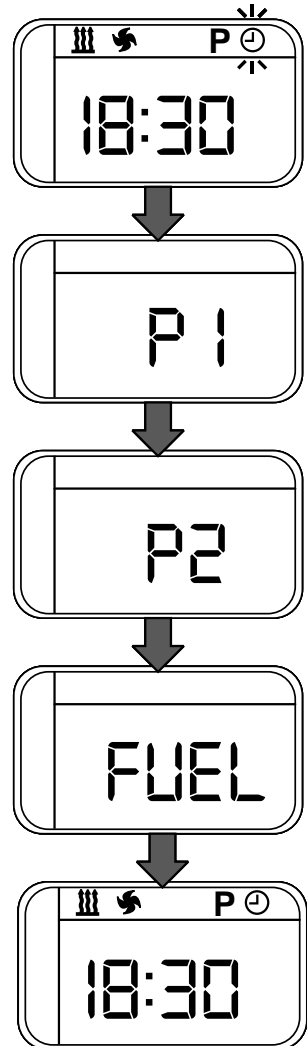

## Checking Error Codes

Once an error code has been displayed, and the problem has been amended, follow these steps to reset it.

1. Check the error using the arrow keys. Exit by pressing either OK or the power button.
2. Press both arrow keys to display message 'dEL'.
3. Press OK to delete all errors or power to go back. Once the display reads 'IE 00' then no errors have been found.
4. Press OK or power to return.

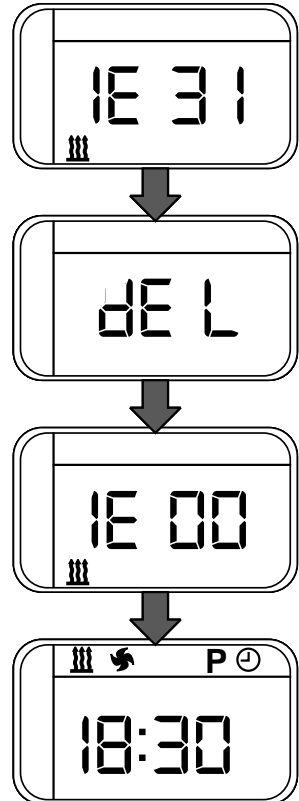



## Resetting Digital Controller to Factory Settings

1. Navigate to the clock face on the menu and simultaneously press both arrow buttons.
2. P1 should appear on the screen.
3. Using the left arrow key select '01', confirm by clicking the 'OK' button.
4. The control should now be reset to its original factory settings.

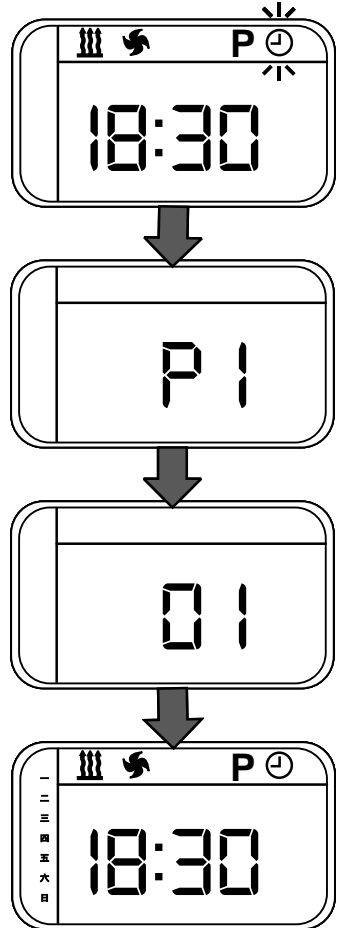

## Maintenance

Once the heater is installed, it should ideally be turned on a few times to remove any air trapped in the fuel lines. Also ensure there is no leaking from the lines and that all electric terminals fit securely together.

You should also regularly:

- Check the air inlet and outlet for any pollution or foreign matters
- Clean the externals of the heater
- Check for corrosion or loose connections of the circuits
- Check the combustion air inlet and exhaust pipe for damage and clogs
- Check the fuel line for leaks

To ensure a long life of the heater it is advised that you run it for at least 10 minutes every month, to prevent malfunction of mechanical parts.

After 10 years the heat exchanger, overheat sensor and exhaust should be replaced by a professional.

If any welding is being attempted on the vehicle, please remove the positive power supply wire and earth it to protect the controller from any damage.

## Fault Codes:

### Rheostat Control

When the ECU had discovered a fault, the rheostat control will flash a fault code. The control should therefore be ideally placed where it can be clearly seen and accessed.

The faults will be displayed as short flashes followed by long flashes. To determine the code, you must count the number of **long** flashes.

Number of Long Flashes	Cause of Problem
<b>1</b>	Failure of second start
<b>2</b>	Termination of the third time of combustion
<b>3</b>	Voltage power out of specified range
<b>4</b>	Glow plug temperature increases slowly
<b>5</b>	<b>Air heaters will not flash 5 times</b>
<b>6</b>	Temperature sensor: Broken circuit or short-circuit
<b>7</b>	Fuel pump: Broken circuit or short-circuit
<b>8</b>	Fan motor: Broken circuit, short-circuit or clogged
<b>9</b>	Glow pin: Broken circuit or short-circuit
<b>10</b>	Overheated
<b>11</b>	Overheat sensor: Broken circuit or short-circuit
<b>12</b>	Control switch: Broken circuit or short-circuit

## Timers

1E-02 : Overheat – Check for obstruction or damaged ducting.

1E-10 : Ignition failure – Check fuel supply, blocked supply or fuel pump.

1E-30 : Voltage too high

1E-31 : Voltage too low – check battery or voltage drop in supply cable

1E-52 : Overheat sensor failure

1E-70 : Fuel pump open circuit or ECU failure

1E-80 : Air motor failure

1E-90 : Glow pin failure.

Thank you for purchasing the BISON 5000A heater.